



B DISPENSERS BATTERY KIT OIL

EN. Portable oil transfer unit featuring 12 or 24 V DC motor pump. Rotary-self-priming pump, fuse to protect against overloads, 2-metre long cables, antistatic fuel hose, 4 metres long, 3/4" diameter, manual nozzle in aluminium, bottom filter.

ES. Grupo portátil para el trasiego de aceite provisto de una bomba con motor de 12 o 24 voltios de corriente continua. Bomba rotatoria, autoalimentada, fusible para protección contra sobrecargas, cables de 2 metros de largo, tubo antiestático para carburantes, 4 metros de largo, 3/4" de diámetro, pistola manual de aluminio, filtro de fondo.

PT. Grupo portátil para drenagem do óleo equipado com bomba com motor a 12 ou 24 Volts de corrente contínua. Bomba rotativa, de disparo automático, fusível para proteção de sobrecargas, cabos de comprimento de 2 metros, tubo antiestático para combustíveis, comprimento de 4 metros, diâmetro 3/4", pistola manual em alumínio, filtro de fundo.

PERFORMANCE

- Flow rate up to 10 l/min
- Power supply: 12 and 24 V dc
- Suction capacity up to 2 meters
- Duty cycle: 30 min.

- Caudal hasta 10 l/min
- Alimentación: 12 y 24 V CC
- Capacidad de aspiración hasta 2 metros
- Ciclo de funcionamiento: 30 min.

- Caudal até 10 l/min
- Alimentação: 12 e 24 V dc
- Capacidade de aspiração até 2 metros
- Ciclo de trabalho: 30 min.



PRODUCTS' RANGE WEIGHT AND PACKAGING

Code	Weight		Packaging		pcs/box
	kg	lbs	mm	inch	
F00309060	9	19,8	360x360x300	14,2x14,2x11,8	1
F00310070	9	19,8	360x360x300	14,2x14,2x11,8	1

ANTIFREEZE
BIO DIESEL
DIESEL
FOOD
GASOLINE
GREASE
KEROSENE
OIL
UREA
WATER
WINDSCREEN

Flow-rate
up to
10 l/min
(up to 3 gpm)

Viscosity
up to
600
cSt



DISPENSERS

PUMPS

METERS

NOZZLE METERS

NOZZLE

SPECIAL EQUIPMENTS

FLUID MONITORING

ACCESSORIES

FILTERING



FEATURES



INCLUDED



ON REQUEST



PRODUCTS' RANGE TECHNICAL DATA

Code	Description	Fluids type	Flow-rate		Voltage			Fuses capacity	Pump mod.	Duty cycle min.	Nozzle type	Hose		Foot filter
			l/min	gpm	AC V/Hz	DC Volt	Power Watt					Amp. max.	length	
BATTERY KIT OIL														
F00309060	Battery Viscomat/12 V		10	3	12	300	22	-	Viscomat DC	30	Man.	4 m	3/4"	YES
F00310070	Battery Viscomat/24 V		10	3	24	300	18	-	Viscomat DC	30	Man.	4 m	3/4"	YES

Upon request it is available with different voltages and 60 Hz frequency



DISPENSERS DRUM VISCOMAT

EN. Diesel transfer unit for non commercial use. Easily connected to drums via a quick 2" coupling. Fitted with a telescopic suction tube for direct connection to fuel drums and nozzle housing located above the drum, near the pump, for easy, clean operations. Fitted with mechanical meters to ensure precise dispensing and control of single user consumption.

ES. Grupo de trasiego de gasóleo para uso privado. Fácil de conectar al bidón mediante conexión rápida de 2". Se suministra con tubo telescópico en aspiración para conectar directamente al bidón y con alojamiento para la pistola situado en las proximidades de la bomba, sobre el bidón, para consentir un uso fácil y limpio del surtidor. Dispone de un cuentalitros mecánico que permite efectuar suministros precisos y administrar el consumo de los distintos usuarios.

PT. Grupo de transferência de gasóleo para uso particular. Fácil de coligar a um tambor mediante um engate rápido de 2". Equipados com tubo telescópico na aspiração para coligar-se directamente ao tambor e com compartimento para guardar a pistola perto da bomba, sobre o tambor, para facilitar a utilização e a limpeza do distribuidor. São equipados com contador de litros mecânico para efectuar abastecimentos com precisão e para a gestão do consumo dos utilizadores individualmente

PERFORMANCE

- AC and DC versions available
- Flow rate up to 25 l/min

- Disponible en versión CA y CC
- Caudal hasta 25 l/min

- Disponível na versão AC e DC
- Caudal até 25 l/min

PRODUCTS' RANGE WEIGHT AND PACKAGING

Code	Weight		Packaging		
	kg	lbs	mm	inch	pcs/box
F0026102D	18	39,6	480x370x265	18,9x14,6x10,4	1
F0026100D	18	39,6	480x370x265	18,9x14,6x10,4	1
F0026200D	18	39,6	480x370x265	18,9x14,6x10,4	1
F00268000	9	19,8	357x357x275	14,1x14,1x10,8	1
F00268010	9	19,8	480x370x265	18,9x14,6x10,4	1
000270000	18	39,6	480x370x265	18,9x14,6x10,4	1
000270010	21	46,3	500x380x280	19,7x15x11	1



Flow-rate
up to
25 l/min
(up to 7 gpm)

Accuracy
+/-
0,5 %

Viscosity
up to
2000
cSt



DISPENSERS



DC DRUM VISCOMAT



AC DRUM VISCOMAT

PUMPS

METERS

NOZZLE METERS

NOZZLE

SPECIAL EQUIPMENTS

FEATURES

ON REQUEST



Ergonomic nozzle

(DC models)



Foot valve

(DC models)



Kit cable



Ergonomic nozzle

(AC models)



Extensible pipe

(AC models)



Mechanical meter

FLUID MONITORING

ACCESSORIES

PRODUCTS' RANGE TECHNICAL DATA

Code	Description	Fluids	Flow-rate		Voltage			Pump	Nozzle	Hoses lenght
		type	l/min	gpm	AC V./Hz DC Volt	Power Watt	Amp. max.	mod.	type	
F0026102D	DRUM Viscomat 200/2 110V/60HZ	☉	9	2	110	1500	15	Viscomat 200/2	Easyoil	4
F0026100D	DRUM Viscomat 200/2 230V/50-60HZ	☉	9	2	230-50/60	800/950	3,8/4,6	Viscomat 200/2	Easyoil	4
F0026200D	DRUM Viscomat 200/2 230V/50/60HZ K400	☉	9	2	230-50/60	800/950	3,8/4,6	Viscomat 200/2	K400	4
F00268000	DRUM Viscomat 60/1 12V	☉	4	1,2	12	150	18,5	Viscomat 60/1	Easyoil	4
F00268010	DRUM Viscomat 60/1 24V K400	☉	4	1,2	24	150	18,5	Viscomat 60/1	K400	4
000270000	DRUM Viscomat 70M	☉	28	7	230	750	4,6	Viscomat 70 M	Self3000	4
000270010	DRUM Viscomat 70M K33	☉	25	7	230	750	4,6	Viscomat 70 M	Self3000	4

The units can also be supplied for operating under different voltages and with meter.

FILTERING

V DISPENSERS ISCOTROLL AC



EN. Viscotroll. Mobile transfer unit. Can be connected to any power socket without requiring compressed air. Supplied with self-priming pump, to ensure constant silent delivery and regular no-pulse flow. 1" BSP suction tube with check valve and filter. 4 metre long, 3/4" BSP delivery pipe. Extras: Meters, Pressure switch with inbuilt safety valve.

Viscotroll 200. Mobile unit for oil transfer. The group comes equipped with a self-priming gear pump and there is also a version with a pressure switch which ensures constant silent delivery and a regular no-pulse flow. 4 meters long 1/2" BSP delivery pipe. Flow meter. Pressure switch with incorporated safety valve.

ES. Viscotroll Unidad móvil de trasiego. Se conecta a cualquier toma de corriente sin necesidad de aire comprimido. Dotada de bomba autocebante, es garantía de caudal constante, regularidad de flujo en ausencia de pulsaciones y silenciosidad. Tubo de aspiración de 1" BSP con válvula de pie y filtro. Tubo de impulsión de 4 metros de largo y de 3/4" BSP. Opcional: Cuentalitros, Presostato con válvula de seguridad incorporada.

Viscotroll 200 Unidad móvil de trasiego de aceite. El grupo lleva instalada una bomba de engranajes autocebante, también disponible en la versión con presostato, que garantiza un caudal constante, un flujo regular con ausencia de pulsaciones y silenciosidad. En la versión con presostato el encendido y el apagado del motor se producen de manera automática al abrir y al cerrar la pistola de suministro. Tubo de impulsión largo 4 metros de 1/2" BSP. Cuentalitros. Presostato con válvula de seguridad incorporada.

PT. Viscotroll. Unidade móvel de transferência. Pode ser coligada a qualquer tomada de corrente sem necessidade de ar comprimido. Equipada com bomba autoescorvante, garantia de vazão constante, regularidade de fluxo sem pulsações e silenciosamente. Tubo de aspiração de 1" BSP com válvula no fundo e filtro. Tubo de descarga de 4 metros de comprimento e 3/4" BSP. Opcionais: Contador de litros, Pressóstato com válvula de segurança incorporada.

Viscotroll 200. Unidade móvel de transferência de óleo. O grupo vem equipado com uma bomba a engrenagens auto-escorvante. Há também uma versão com pressostato, que garante uma vazão constante e silenciosa e um débito regular com ausência de pulsos. Tubo de vazão de BSP de 1/2" com 4 metros de extensão. Medidor de fluxo. Pressostato com válvula de segurança incorporada.

PERFORMANCE

- Flow rate up to 25 l/min
- 230 V continuous AC operation
- Noise level below 70 dB

- Caudal hasta 25 l/min
- Funcionamiento continuo CA 230 V
- Nivel sonoro inferior a 70 dB

- Caudal até 25 l/min
- Funcionamento contínuo AC 230 V
- Ruído inferior a 70 dB

DIMENSIONS

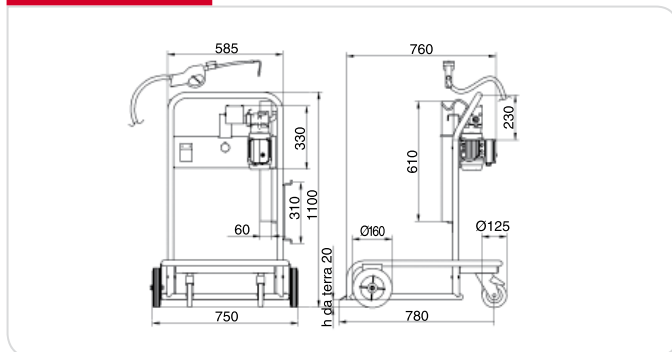

PRODUCTS' RANGE WEIGHT AND PACKAGING

Code	Weight		Packaging		pcs/box
	kg	lbs	mm	inch	
VISCOTROLL					
000263100	34	75	1090x690x300	42,9x27,2x11,8	1
000263110	36	79,4	1090x690x300	42,9x27,2x11,8	1
VISCOTROLL 200					
F0026300D	34	75	1090x690x300	42,9x27,2x11,8	1
F0026301D	35	77	1090x690x300	42,9x27,2x11,8	1
F0026302D	36	79,4	1090x690x300	42,9x27,2x11,8	1
F0026303D	37	81,6	1090x690x300	42,9x27,2x11,8	1



Drum not included

Flow-rate
up to
25 l/min
(up to 7 gpm)

Accuracy
+/-
0,5 %

Viscosity
up to
2000
cSt



DISPENSERS



PUMPS

METERS



NOZZLE METERS

NOZZLE

SPECIAL EQUIPMENTS

FEATURES

ON REQUEST



FLUID MONITORING

ACCESSORIES

PRODUCTS' RANGE TECHNICAL DATA

Code	Description	Fluids type	Flow-rate		Viscosity cSt max.	Voltage			Meter mod.	Pump mod.	Nozzle type
			l/min	gpm		AC V./Hz DC Volt	Power Watt	Amp. max.			
VISCOTROLL											
000263100	Viscotroll 70	BDO	25	6,6	2000	230/50	750	4,6	-	Viscomat vane	Self 3000
000263110	Viscotroll 70/K33	BDO	25	6,6	2000	230/50	750	4,6	K33	Viscomat vane	Self 3000
VISCOTROLL 200											
F0026300D	Viscotroll 200/2 AC	BDO	9	2,4	2000	230/50	800	3,8	-	Visco-flowmat	Easyoil
F0026301D	Viscotroll 200/2 AC - K400	BDO	9	2,4	2000	230/50	800	3,8	K400	Visco-flowmat	Easyoil
F0026302D	Viscotroll 200/2 AC - PST	BDO	9	2,4	2000	230/50	800	3,8	-	Visco-flowmat	Easyoil
F0026303D	Viscotroll 200/2 AC - PST - K400	BDO	9	2,4	2000	230/50	800	3,8	K400	Visco-flowmat	Easyoil

Upon request it is available with different voltage and frequency

FILTERING

V DISPENSERS ISCOTROLL DC



EN. Independent mobile unit without using compressed air or power mains, for oil dispensing anywhere. Trailer mounted support for moving the drums. Self-priming pump with 12 VDC motor, protection rating IP 55.

Options:
Flow meter with oval gears.

ES. Unidad móvil independiente para el suministro de aceite incluso allí donde no existe una instalación de aire comprimido o una toma de corriente eléctrica. Soporte sobre ruedas portabidón. Bomba autocebante con motor de corriente continua alimentada a 12 V; protección IP55.

Opciones:
Cuentalitos de engranajes ovalados.

PT. Unidade móvel independente para fornecer óleo mesmo onde não houver sistema de ar comprimido nem tomada de corrente elétrica. Carrinho transportador do barril. Bomba auto-escorvante com motor de corrente contínua alimentada a 12 V, proteção IP55

Opcionais:
Contador de litros de engrenagens ovais.

PERFORMANCE

- Flow rate up to 6 l/min
- Accuracy +/- 0,5 %
- Viscosity up to 2000 cSt
- Noise level below 65 dB
- Engine power supply voltage 12 Vdc
- Switching on/ off of automatic pump with pressure switch

- Caudal hasta 6 l/min
- Precisión +/- 0,5 %
- Viscosidad hasta 2000 cSt
- Nivel sonoro inferior a 65 dB
- Tensión de alimentación motor 12 Vcc
- Encendido / apagado bomba automática con presostato

- Caudal até 6 l/min
- Precisão +/- 0,5 %
- Viscosidade até 2000 cSt
- Nível de ruído inferior a 65 dB
- Tensão de alimentação do motor 12 Vdc
- Activação/desactivação da bomba automática com pressóstato

DIMENSIONS

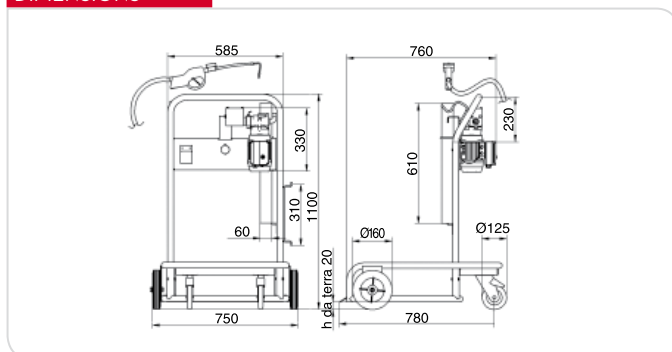

PRODUCTS' RANGE WEIGHT AND PACKAGING

Code	Weight		Packaging		
	kg	lbs	mm	inch	pcs/box
VISCOTROLL 120/1					
F00263200	57	125,7	1090x690x320	42,9x27,2x12,6	1
F00263210	58	125,9	1090x690x320	42,9x27,2x12,6	1
F00263220	58	125,9	1090x690x320	42,9x27,2x12,6	1

Flow-rate
up to
6 l/min
(up to 1,6 gpm)

Accuracy
+/-
0,5 %

Viscosity
up to
2000 cSt



DISPENSERS



Drum not included

Optional: flow meter with oval gear

Viscotroll DC



PUMPS

METERS

NOT NETWORK ENERGY

NOT AIR COMPRESSOR

YES ENERGY INDEPENDENCE

— +

NOZZLE METERS

NOZZLE

SPECIAL EQUIPMENTS

FEATURES



ON REQUEST

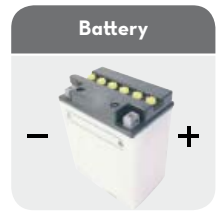

Code R12068010

FLUID MONITORING

ACCESSORIES

FILTERING

PRODUCTS' RANGE TECHNICAL DATA

Code	Description	Fluids type	Flow-rate		Battery charger Volt	Viscosity cSt max.	Voltage			Meter mod.	Pump mod.	Nozzle type
			l/min	gpm			AC V/Hz	DC Volt	Power Watt			
F00263200	Viscotroll 120/1 DC pst.		6	1,6	230	2000	12	360	30	K400	Viscomat DC	Easyoil
F00263210	Viscotroll 120/1 DC pst. K400		6	1,6	230	2000	12	360	30	K400	Viscomat DC	Easyoil
F00263220	Viscotroll 120/1 DC pst. K400 100V/120V		6	1,6	120	2000	12	-	-	K400	Viscomat DC	Easyoil