



Art. no. **8318 - 8319**

Pneumatic double diaphragm pump, selfpriming up to 5 m suction lift, working also in dry running condition, without any electric drive, suitable for the use also with fluids of higher viscosity and for fluids containing particles up to 3 mm size, body in PP, diaphragms in NBR + PTFE, balls in PTFE, o – rings in EPDM, seats in PP.

Art. no.	Max flow rate	Max suction lift	Compressed air supply	Connection compressed air inlet	Connections fluid	Consumption compressed air	Weight	Dimensions (LxWxH) (mm)
<b>8318</b>	20 l/min	5 m	2 - 7 bar	1/4" (F)	3/8" (M)	160 l/min	1,2 kg	145x95x160
<b>8319</b>	50 l/min	5 m	2 - 7 bar	3/8" (F)	1/2" (M)	200 l/min	6,5 kg	222x156x233



Art. no. **8320 - 8321**

Pneumatic double diaphragm pump, suitable for the use in areas exposed to explosion hazards, approved in accordance with directive ATEX 94/9/EC - zone 2.

Working also in dry running condition, selfpriming up to 6 m suction lift, without any electric drive, suitable for the use also with fluids of higher viscosity and for fluids containing particles up to 7,5 mm size, body in aluminium, diaphragms in Hytrel® + PTFE, balls in PTFE, o – rings in Viton®, seats in aluminium.

Art. no.	Max flow rate	Max suction lift	Compressed air supply	Connection compressed air inlet	Connections fluid	Consumption compressed air	Weight	Dimensions (LxWxH) (mm)
<b>8320</b>	100 l/min	6 m	2 - 7 bar	1/2" (F)	3/4" (M)	250 l/min	7 kg	265x175x245
<b>8321</b>	165 l/min	6 m	2 - 7 bar	1/2" (F)	1" (M)	800 l/min	15 kg	370x222x365

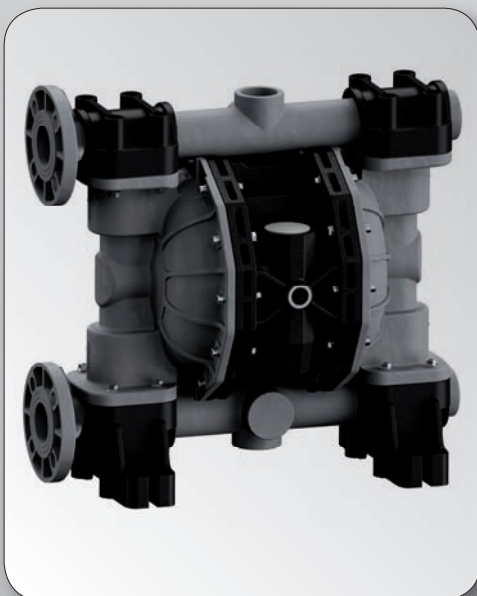

Art. no. **8322 - 8323**

Pneumatic double diaphragm pump, suitable for the use in areas exposed to explosion hazards, approved in accordance with directive ATEX 94/9/EC - zone 2.

Working also in dry running condition, selfpriming up to 6 m suction lift, without any electric drive, suitable for the use also with fluids of higher viscosity and for fluids containing particles up to 8,5 mm size, body in aluminium, diaphragms in Hytrel® + PTFE, balls in PTFE, o – rings in Viton®, seats in aluminium.

Art. no.	Max flow rate	Max suction lift	Compressed air supply	Connection compressed air inlet	Connections fluid	Consumption compressed air	Weight	Dimensions (LxWxH) (mm)
<b>8322</b>	250 l/min	6 m	2 - 7 bar	1/2" (F)	1'1/4" (M)	900 l/min	16 kg	370x220x364
<b>8323</b>	680 l/min	6 m	2 - 7 bar	3/4" (F)	2" (M)	2400 l/min	36 kg	595x340x572